

MSI-3360 CHALLENGER 2 SPECIFICATIONS

The MSI-3360 crane scale is an ideal unit for the cost-conscious user for light capacity use. For higher capacities, heavy-duty, outdoor and continuous production use, MSI recommends: MSI-4260, MSI-4300 or MSI-6260.

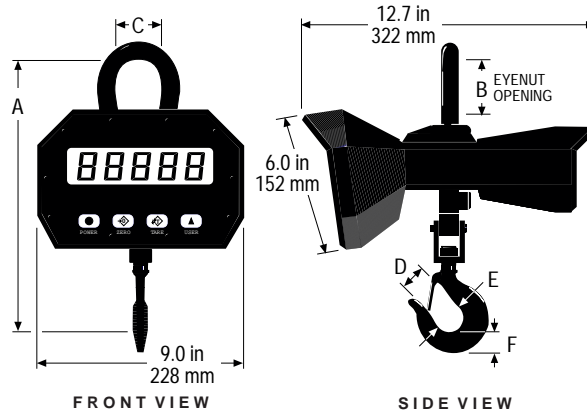

DIMENSIONS AND SPECIFICATIONS

CAPACITY	RESOLUTION	A	B	C	D	E	F	APPROX. SHIP WT.
250 lbs	0.1 lb	11.94 in	2.45	2.0	1.12	1.63	1.12	22 lb
125 kgs	.05 kg	303 mm	62	51	28	41	28	10 kg
500 lbs	0.2 lb	11.94 in	2.45	2.0	1.12	1.63	1.12	22 lb
250 kgs	0.1 kg	303 mm	62	51	28	41	28	10 kg
1,000 lbs	0.5 lb	11.94 in	2.45	2.0	1.12	1.63	1.12	22 lb
500 kgs	0.2 kg	303 mm	62	51	28	41	28	10 kg
2,000 lbs	1 lb	11.94 in	2.45	2.0	1.12	1.63	1.12	22 lb
1,000 kgs	0.5 kg	303 mm	62	51	28	41	28	10 kg
5,000 lbs	2 lb	16.67 in	3.40	2.45	1.80	2.5	1.81	39 lb
2,500 kgs	1 kg	423 mm	86	62	46	64	46	18 kg
10,000 lbs	5 lb	16.67 in	3.40	2.45	1.80	2.5	1.81	39 lb
5,000 kgs	2 kg	423 mm	86	62	46	64	46	18 kg
15,000 lbs	5 lb	21.58 in	4.28	3.25	1.95	3.00	2.25	56 lb
7,000 kgs	2 kg	548 mm	109	83	50	76	57	26 kg

CONSULT FACTORY FOR HIGHER CAPACITIES. SPECIFICATIONS SUBJECT TO CHANGE.

STANDARD PRODUCT SPECS

Accuracy: Plus or minus 0.1% of applied load
Display: 5 digit, 1.2 in/30 mm high manual or photocell LED brightness control
Filtering: Low, Medium or High selectable
Units: Pounds or Kilograms selectable
Resolution: 2000 or 2500 divisions standard (up to 10,000 available)
Power: 6 volt rechargeable battery (115 or 230 VAC charger included)
Operating Time: 50 hrs. min./100 hrs. max. (depends on operating mode)
Auto-Off Mode: Select for 12 min., 1 hr. or Off
Auto-Sleep Mode: Power down during non-use and power up with motion for maximum battery conservation
Service Counter: Registers number of lifts by value for inspection and maintenance reminder
Operating Temperature Range: -4° to +122° F (-20° to +50°C)
Enclosure: NEMA 12/IP54 powder coated Alodined Cast Aluminum
Hook: Crosby-Laughlin or equivalent 360° non-bearing swivel
Safe Overload: 200% of rated capacity
Ultimate Overload: 500% of rated capacity

FUNCTION SWITCHES AND LIGHTS

POWER: Turns unit ON or OFF
ZERO: Zeros applied load up to 100% of capacity (limited range with NIST or OIML option)
TARE: Tares out applied load and displays weight in Net mode. Push again to return to Gross mode
USER: User programmable multifunction switch for use as TEST, UNIT select, TOTAL (auto or manual), PEAK HOLD and SET POINTS
ANNUNCIATORS: Center of Zero, Net, Gross, Total, Peak, x 1000, Battery, lb/kg, Motion, SP1 and SP2

OPTIONS AND ACCESSORIES

- NTEP (86-021A2), OIML and EC (T2943) approved versions (Contact factory for specifications)
- Infrared remote controller with 8 meter operating range
- 115 or 230 VAC input power
- Special capacity or displayable resolution

OTHER HEAVY-DUTY MSI CRANE SCALES

For heavy-duty, high heat or hazardous use applications, See MSI-4260 Port-A-Weigh specification sheet. Capacities from 500 lb to 500,000 lb (250 kg to 250,000 kg).

For heavy-duty and multi-task applications, See MSI-4300 Porta-Weigh Plus specification sheet. Capacities from 500 lb to 500,000 lb (250 kg to 250,000 kg).

For heavy-duty applications requiring remote radio telemetry display and/or computer/printer interface, see MSI-6260 Trans-Weigh specification sheet. Capacities from 500 lb to 500,000 lb (250 kg to 250,000 kg).



Dynamic Measurement Systems, LLC
 Sales, Service, Rentals
 Web: www.dynmeasure.com
 email: dyna@dynmeasure.com
 Address: 16515 Hedgcroft, Suite 320
 Houston, TX 77060
 Phone: 281.405.0606
 Fax: 281.405.0303